

FICHA DE INSTALACIÓN Y REGULACIÓN

maestre

BAÑOS



INSTALACIÓN Y REGULACIÓN DE MUEBLES

EN: Furniture installation and adjustment. **/FR:** Installation et réglementation des meubles. **/PT:** Instalação e regulação de móveis

MUEBLES SUSPENDIDOS, MODULO CAJON Y MODULO ESTANTE

EN: Suspended furniture, drawer module, and shelf module. **/FR:** Meubles suspendus, module tiroir et module étagère. **/PT:** Móveis suspensos, módulo gaveta e módulo prateleira

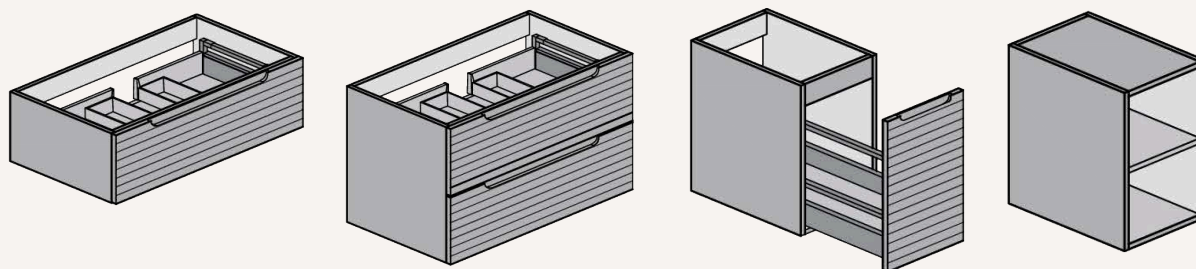

DESEMBALAJE

EN: Unpacking. **/FR:** Déballage. **/PT:** Desempacotando

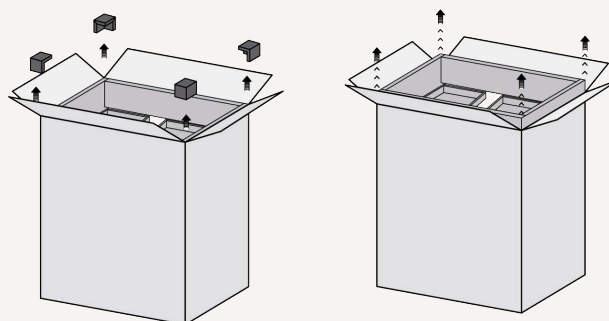

MUEBLE BAJO SUSPENDIDO Y PLACA DE SUJECIÓN EN PARED

EN: Suspended base furniture and wall mounting plate. **/FR:** Meuble bas suspendu et plaque de fixation murale. **/PT:** Móvel suspenso e placa de fixação na parede.

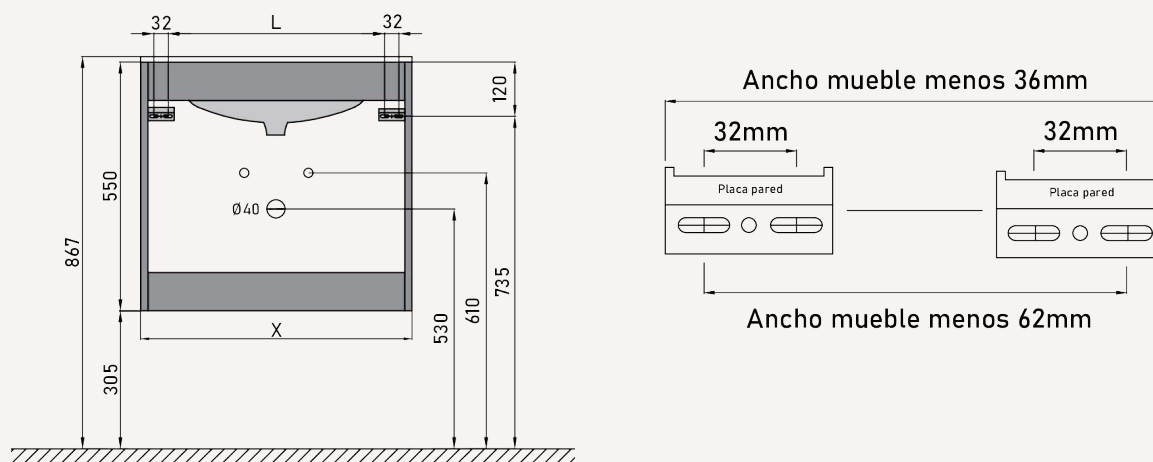

DOBLE SUJECIÓN A PARED EN BARRA TRASERA

EN: Double wall mounting on the back bar. **/FR:** Double fixation murale sur la barre arrière. **/PT:** Dupla fixação na parede na barra traseira.

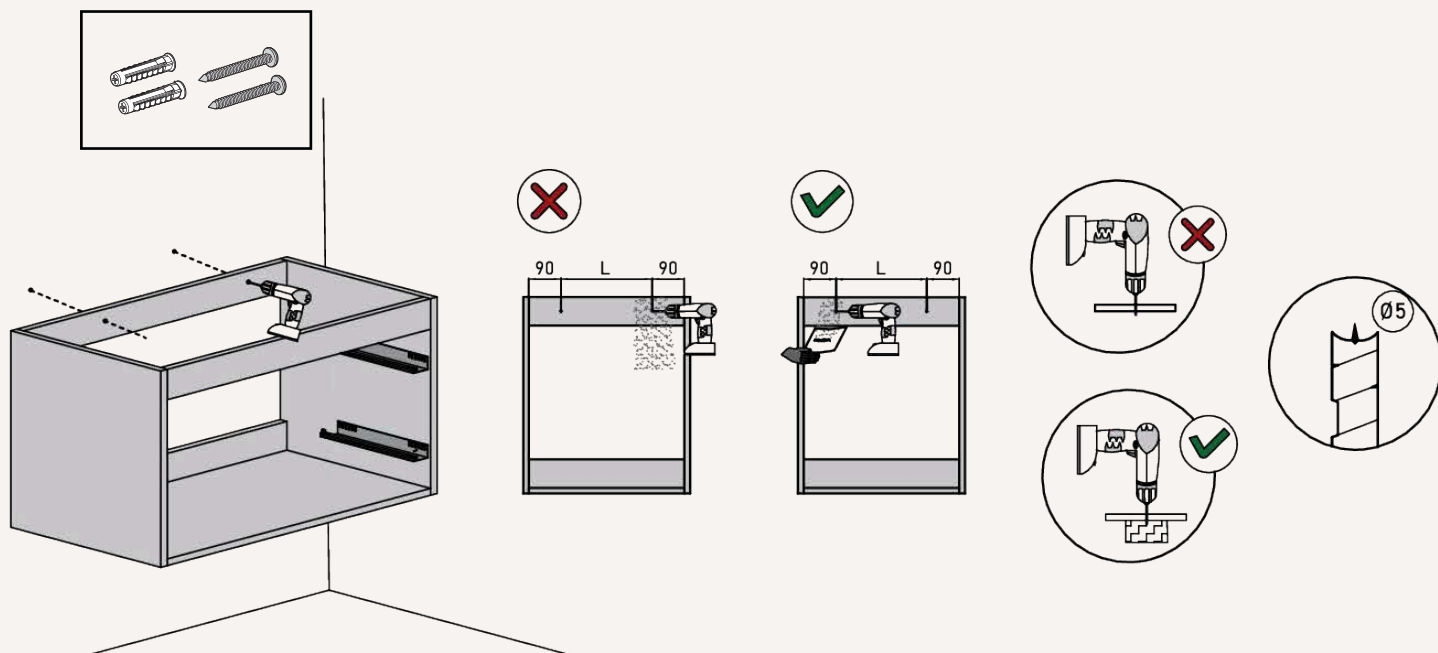

SUJECIÓN COLGADOR SCARPI

EN: SCARPI hanger mounting. **/FR:** Fixation du porte-vêtements SCARPI. **/PT:** Fixação do cabide SCARPI.

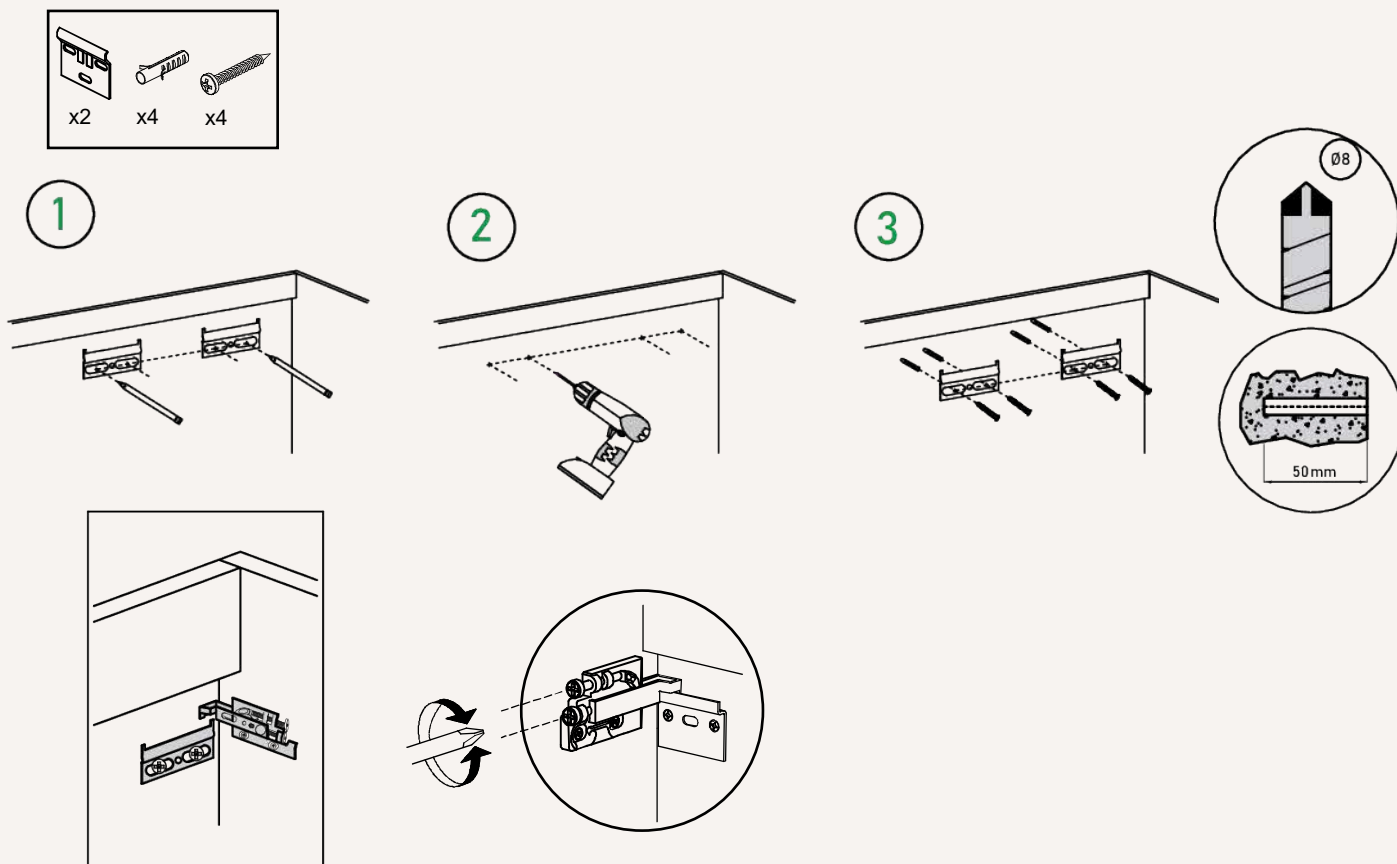

SUJECIÓN DE MUDULO ESTANTE A PARED

EN: Wall mounting of shelf module. **/FR:** Fixation du module étagère au mur. **/PT:** Fixação do módulo de prateleira na parede.

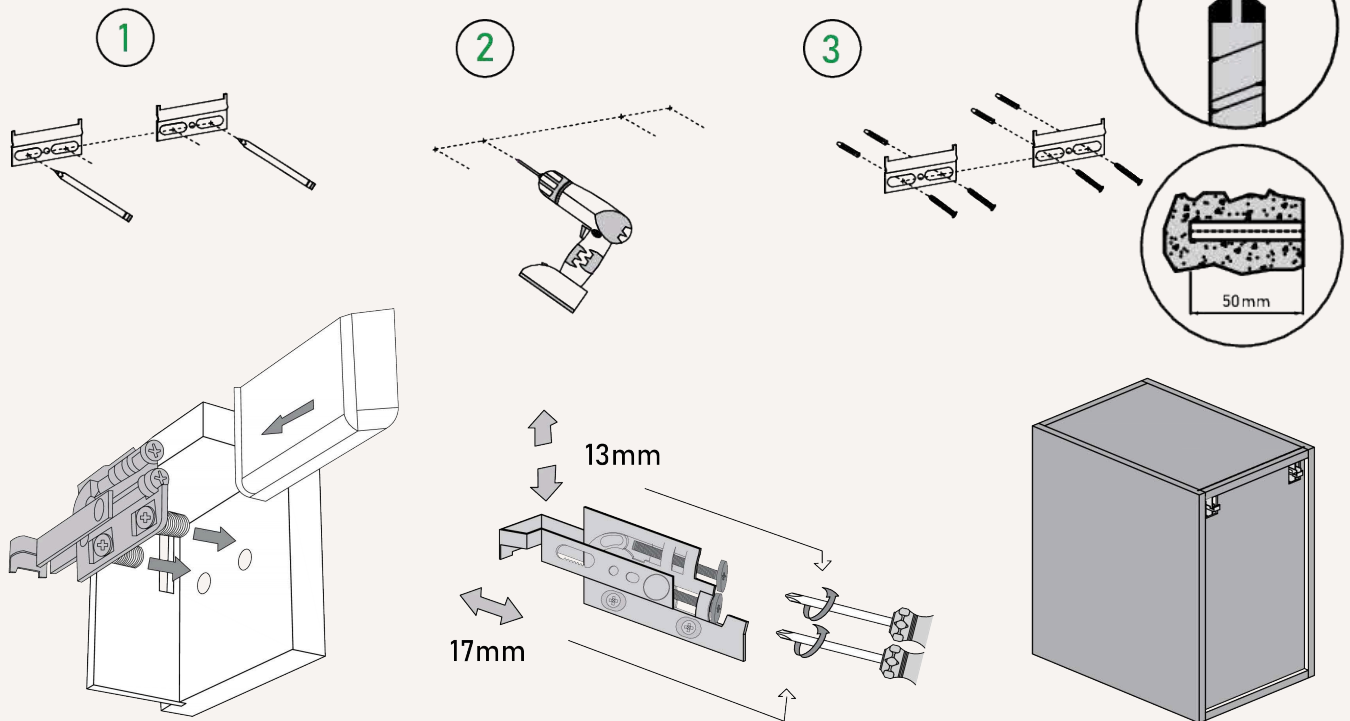
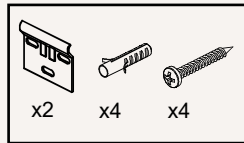

UNIÓN DE MUEBLES

EN: Joining of furniture. **/FR:** Union de meubles. **/PT:** União de móveis.

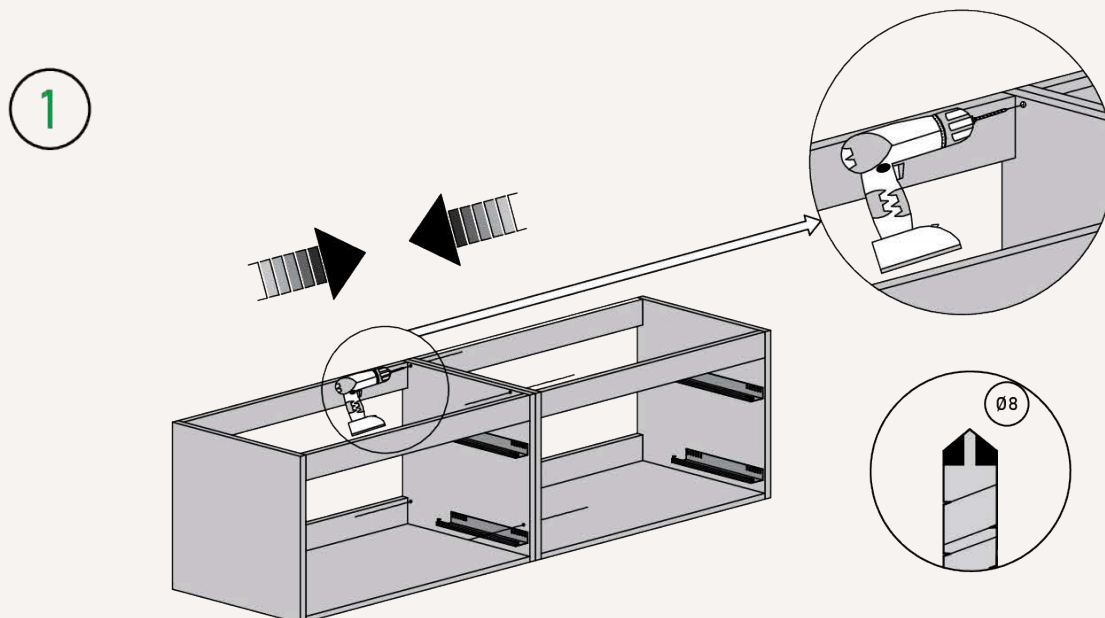

UNION DE MUEBLES Y MODULOS

EN: Joining of furniture and modules /FR: Union de meubles et de modules. /PT: União de móveis e módulos.

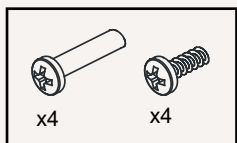

2

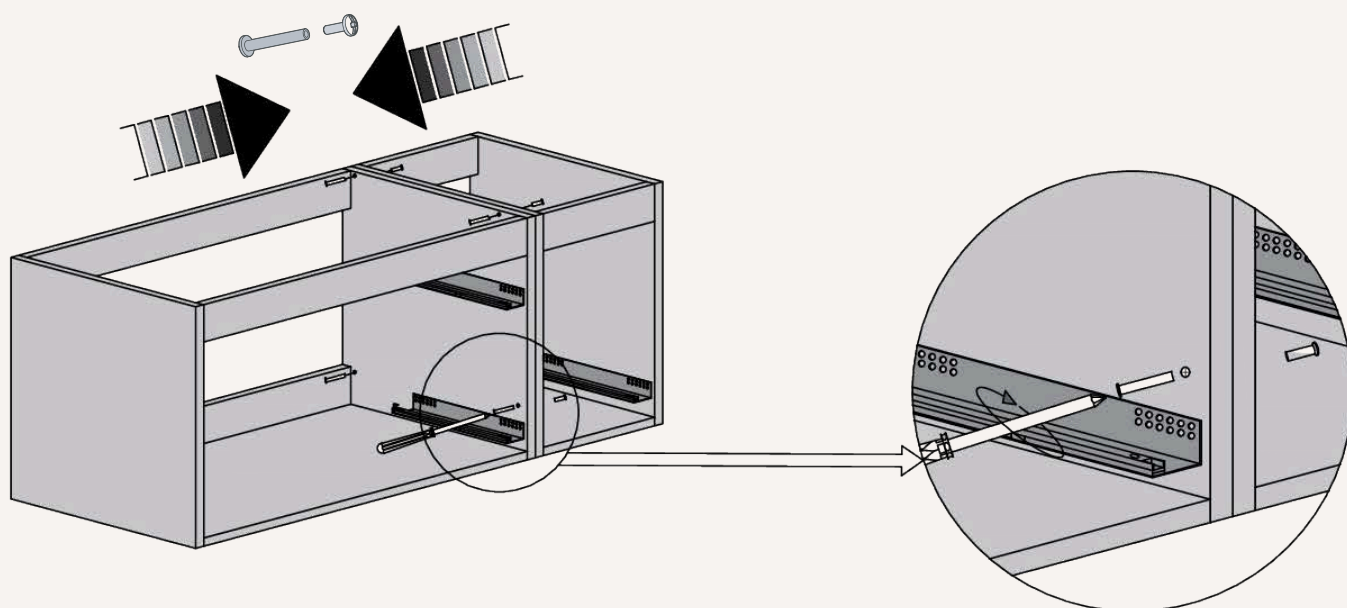
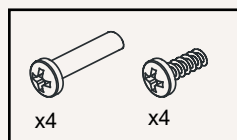
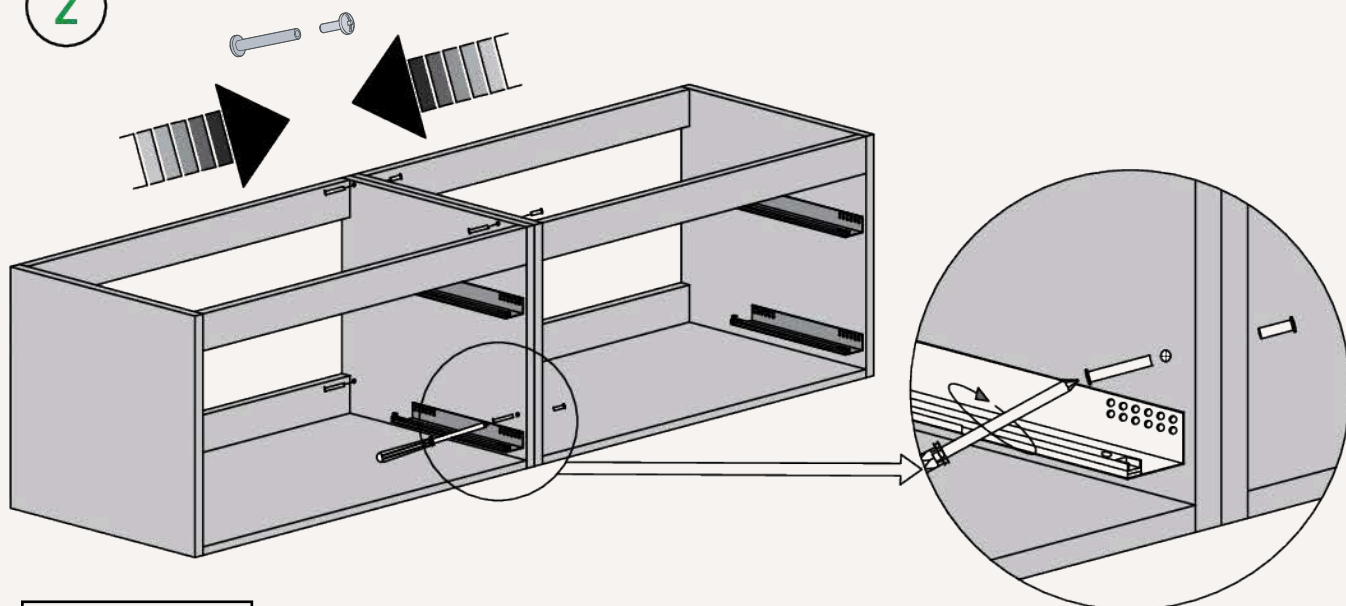

COLOCACIÓN ENCIMERA Y BOLS

EN: Installation of countertop and bowls. **/FR:** Installation du plan de travail et des bols. **/PT:** Colocação da bancada e das pias.

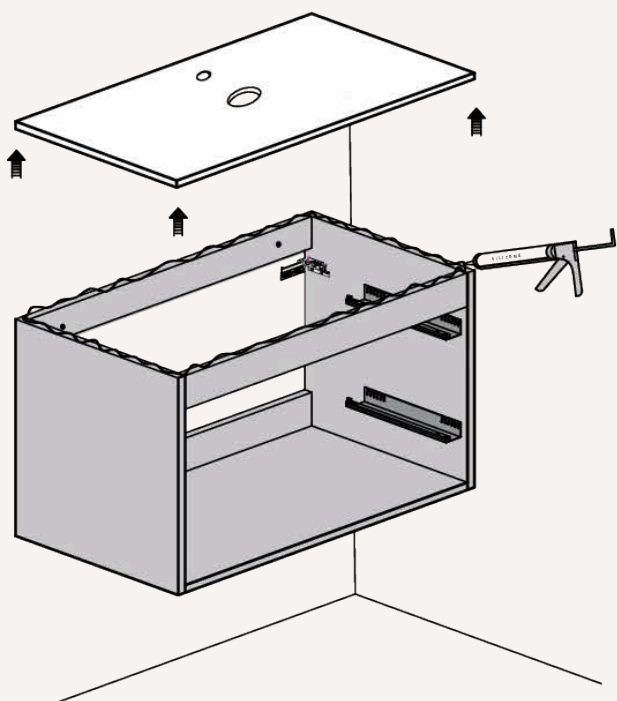
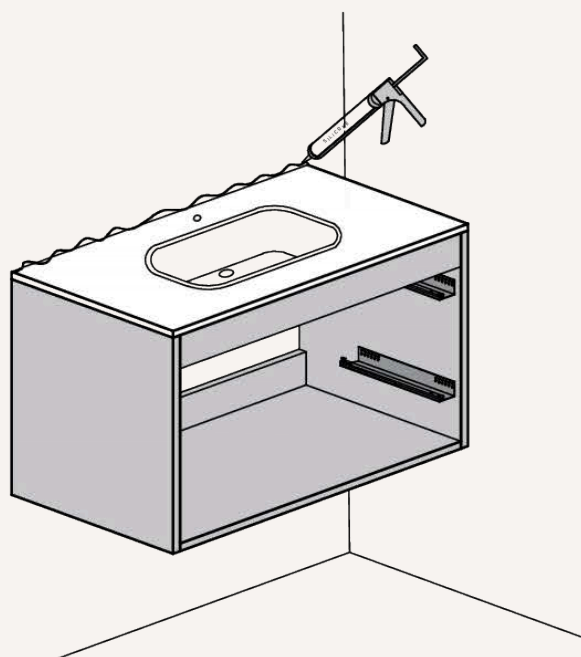
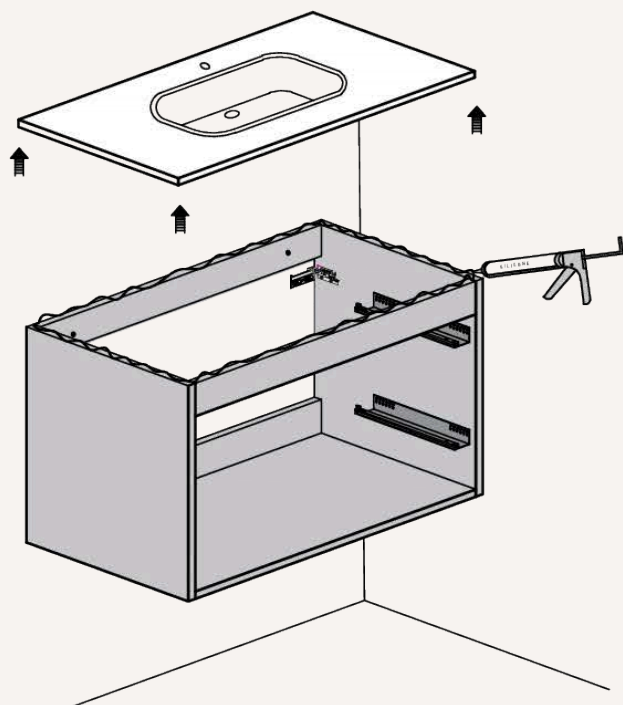

CAJÓN ALTA GAMA INNOTECH (HETTICH)

EN: High-end INNOTECH drawer (HETTICH). **/FR:** Tiroir haut de gamme INNOTECH (HETTICH). **/PT:** Gaveta de alta gama INNOTECH (HETTICH).

RETIRANDO EL CAJÓN

EN: Removing the drawer.
FR: Retrait du tiroir.
PT: Retirando a gaveta.

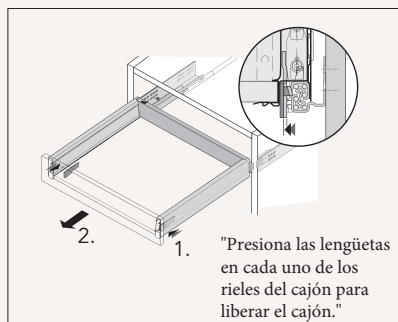

INSERTANDO EL CAJÓN

EN: Inserting the drawer.
FR: Insérer le tiroir.
PT: Inserindo a gaveta.

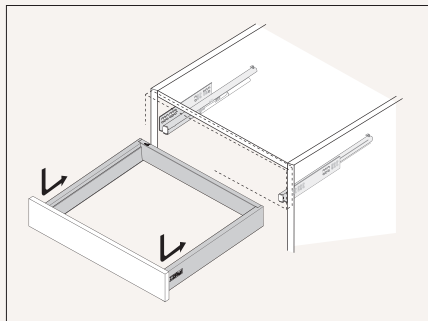

RETIRANDO/INSTALANDO LA TAPA

EN: Removing/Installing the lid.
FR: Retrait/Installation du couvercle.
PT: Retirando/Instalando a tampa.

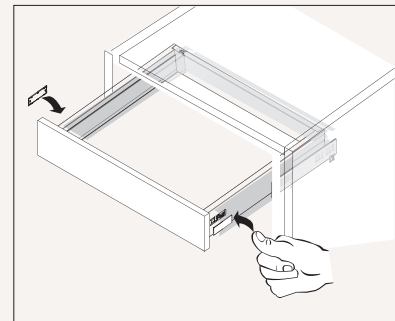

EN: Press the tabs on each of the drawer runners to release the drawer. **/FR:** Appuyez sur les languettes de chaque rail du tiroir pour libérer le tiroir. **/PT:** Pressione as linguetas em cada um dos trilhos da gaveta para liberar a gaveta.

AJUSTE DE ALTURA

EN: Height adjustment.
FR: Réglage de la hauteur.
PT: Ajuste de altura.

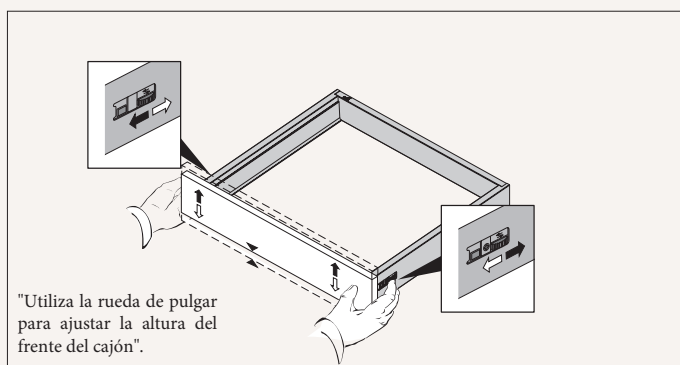

EN: Use the thumb wheel to adjust the height of the drawer front.
FR: Utilisez la molette pour régler la hauteur du devant du tiroir.
PT: Use a roda de polegar para ajustar a altura da frente da gaveta.

AJUSTE LATERAL

EN: Lateral adjustment.
FR: Réglage latéral.
PT: Ajuste lateral.

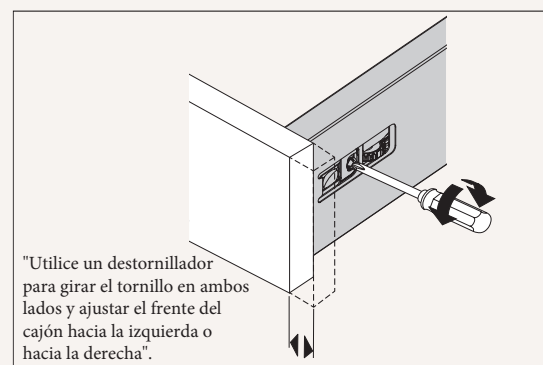

EN: Use a screwdriver to turn the screw on both sides and adjust the drawer front to the left or right.
FR: côté et ajuster le devant du tiroir vers la gauche ou vers la droite.
PT: Use uma chave de fenda para girar o parafuso de ambos os lados e ajustar a frente da gaveta para a esquerda ou para a direita.

AJUSTE DE INCLINACIÓN

EN: Tilt adjustment.
FR: Réglage de l'inclinaison.
PT: Ajuste de inclinação.

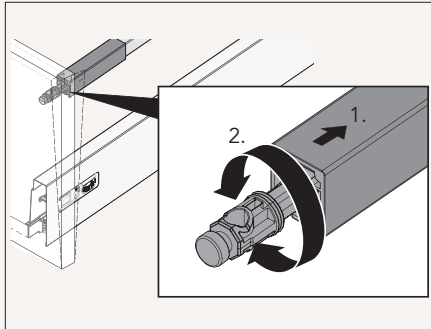

RETIRADA DEL RAIL

EN: Railing removal.
FR: Retrait du rail.
PT: Remoção do trilho.

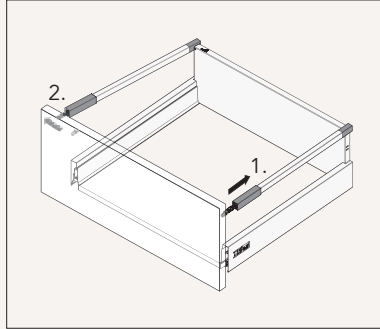

INSTALACIÓN DEL RAIL

EN: Railing installation.
FR: Installation du rail.
PT: Instalação do trilho

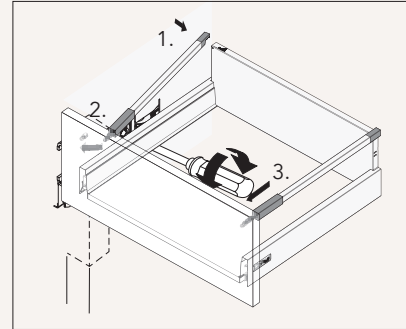

RETIRADA DEL FRENTE DEL CAJÓN

EN: Drawer front removal.
FR: Retrait du devant du tiroir
PT: Remoção da frente da gaveta

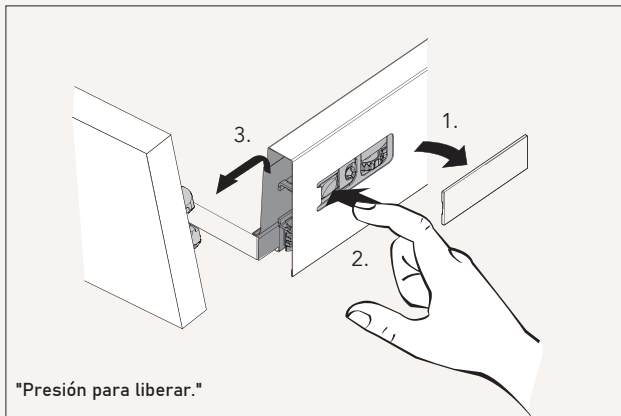

INSTALACIÓN DEL FRENTE DEL CAJÓN

EN: Drawer front installation.
FR: Retrait du devant du tiroir
PT: Remoção da frente da gaveta.

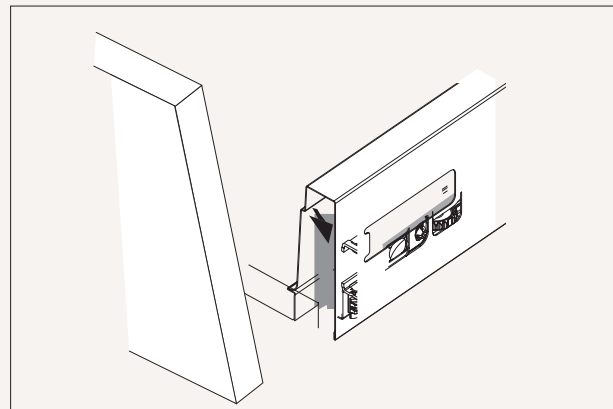

MANTENIMIENTO Y LIMPIEZA DE MUEBLES

EN: Maintenance and cleaning of furniture /**FR:** Entretien et nettoyage des meubles. /**PT:** Manutenção e limpeza de móveis.

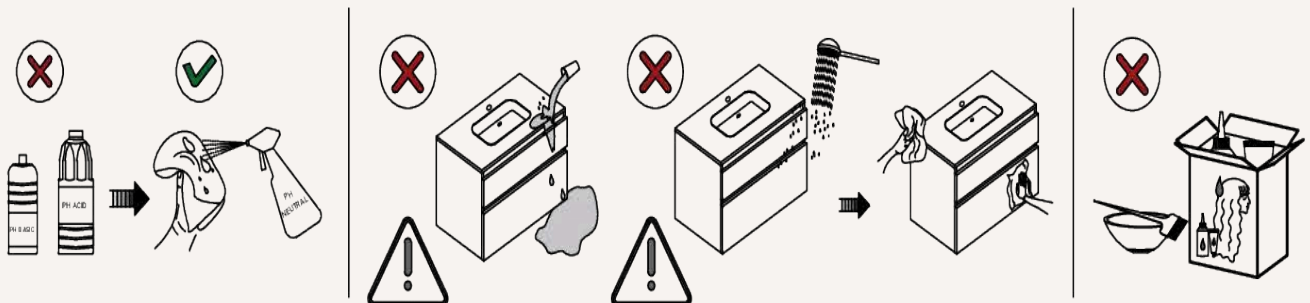

INSTALACIÓN Y REGULACIÓN DE MUEBLES

EN: Furniture installation and adjustment. /FR: Installation et réglementation des meubles. /PT: Instalação e regulação de móveis

MUEBLE DE TRES CAJONES CON PATAS

EN: Three-drawer cabinet with legs. /FR: Meuble trois tiroirs avec pieds. /PT: Móvel de três gavetas com pés.

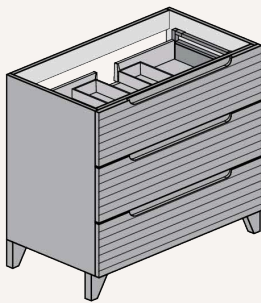

DESEMBALAJE

EN: Unpacking. /FR: Déballage. /PT: Desempacotando

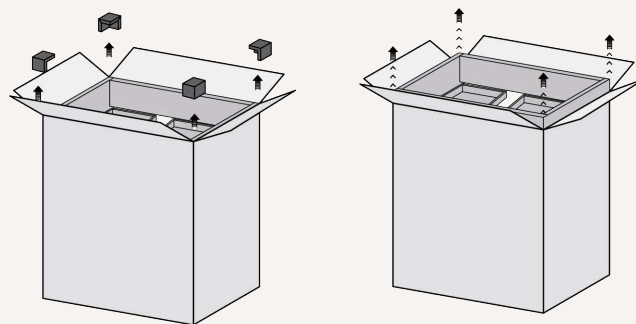

PATAS

EN: Legs. /FR: Pieds. /PT: Pés.

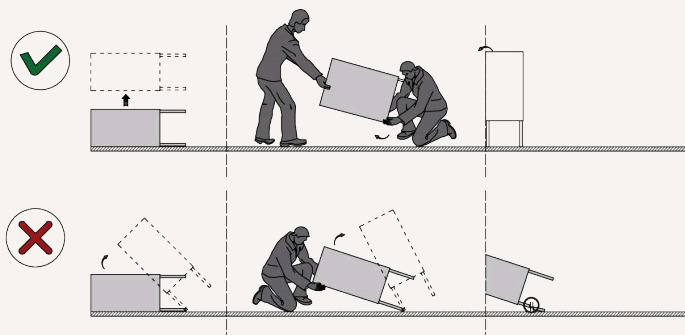
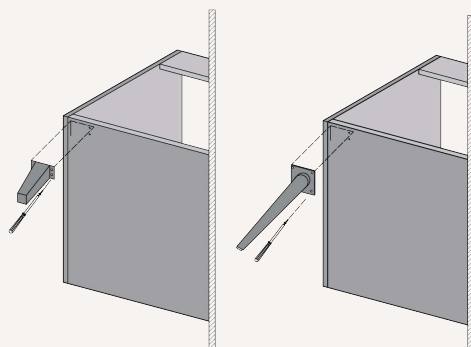
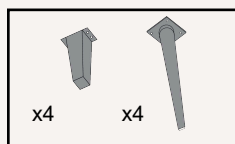

SUJECCIÓN A PARED BARRA TRASERA

EN: Wall mounting back bar. /FR: Fixation murale de la barre arrière. /PT: Fixação na parede da barra traseira.

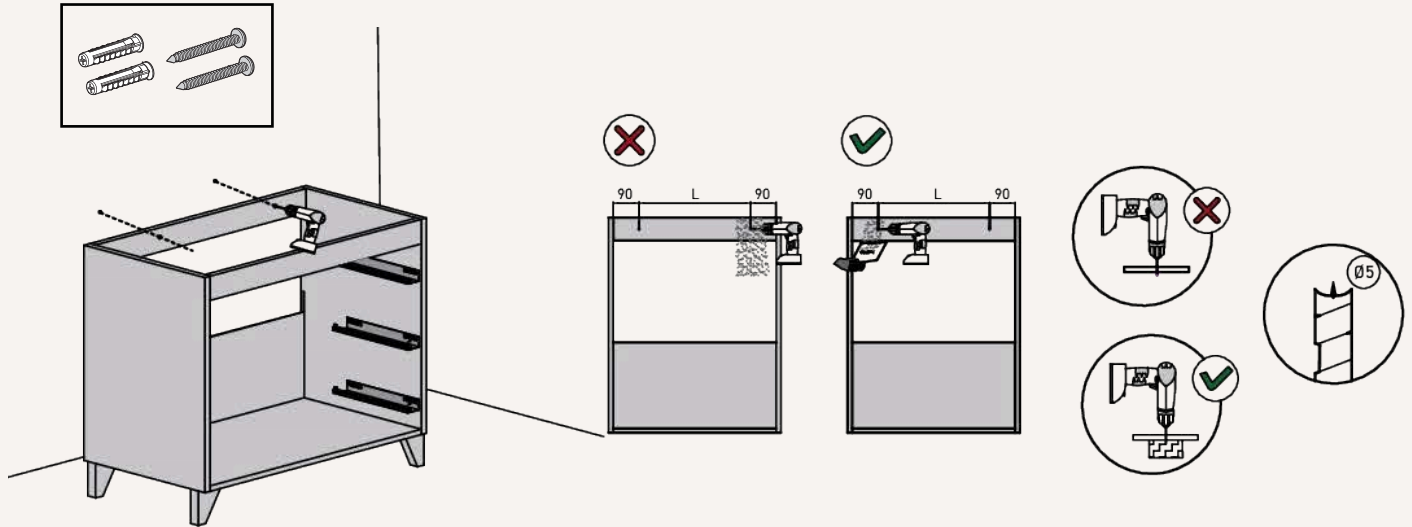

COLOCACIÓN ENCIMERA Y BOLS

EN: Installation of countertop and bowls. /FR: Installation du plan de travail et des bols. /PT: Colocação da bancada e das pias.

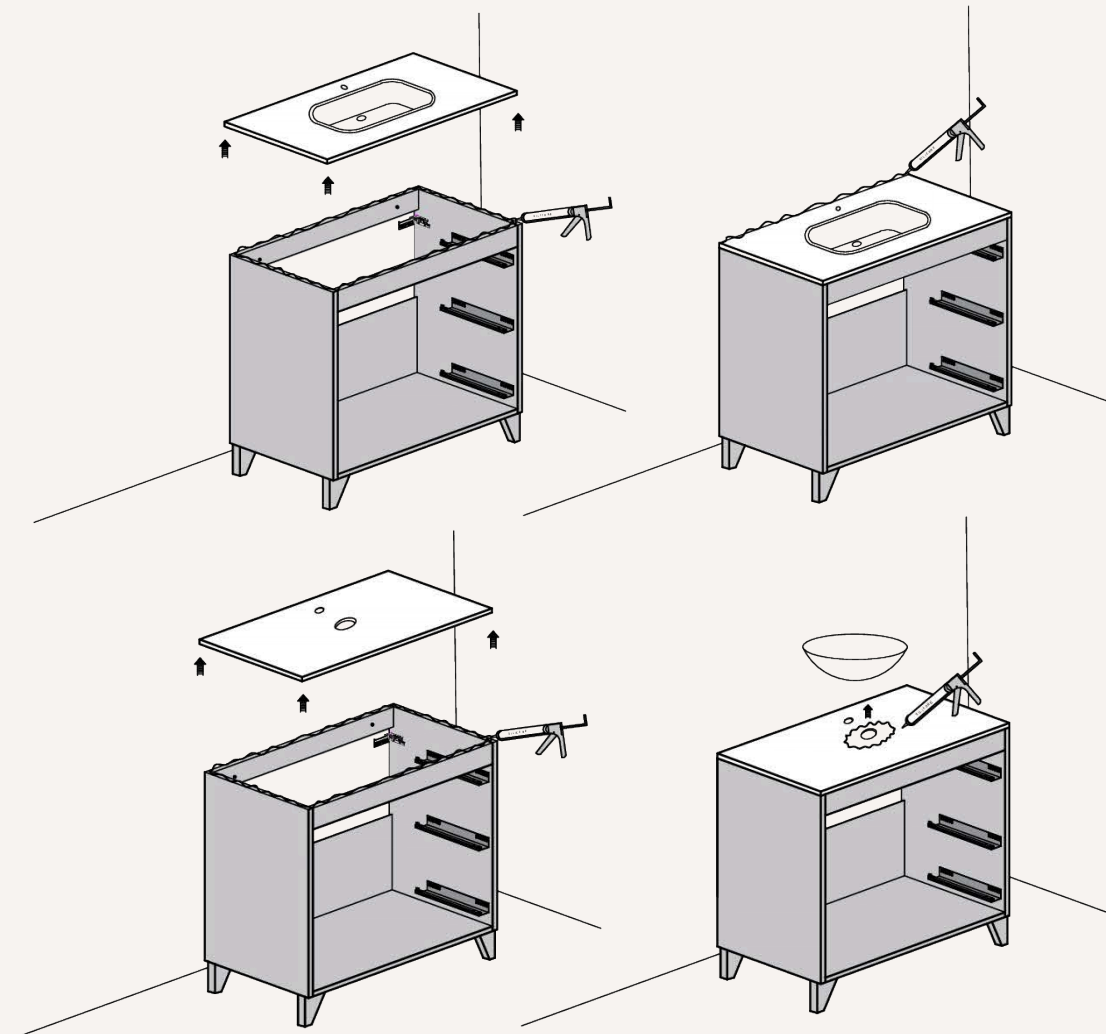

CAJÓN ALTA GAMA INNOTECH (HETTICH)

EN: High-end INNOTECH drawer (HETTICH). **/FR:** Tiroir haut de gamme INNOTECH (HETTICH). **/PT:** Gaveta de alta gama INNOTECH (HETTICH).

RETIRANDO EL CAJÓN

EN: Removing the drawer.
FR: Retrait du tiroir.
PT: Retirando a gaveta.

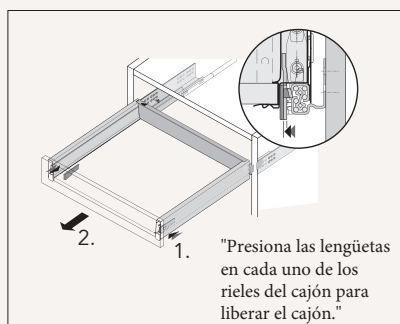

INSERTANDO EL CAJÓN

EN: Inserting the drawer.
FR: Insérer le tiroir.
PT: Inserindo a gaveta.

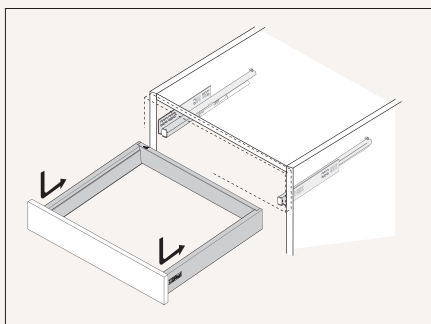

RETIRANDO/INSTALANDO LA TAPA

EN: Removing/Installing the lid.
FR: Retrait/Installation du couvercle.
PT: Retirando/Instalando a tampa.

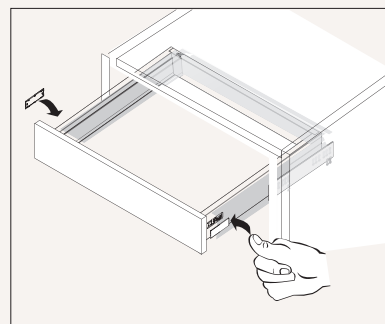

EN: Press the tabs on each of the drawer runners to release the drawer. **/FR:** Appuyez sur les languettes de chaque rail du tiroir pour libérer le tiroir. **/PT:** Pressione as linguetas em cada um dos trilhos da gaveta para liberar a gaveta.

AJUSTE DE ALTURA

EN: Height adjustment.
FR: Réglage de la hauteur.
PT: Ajuste de altura.

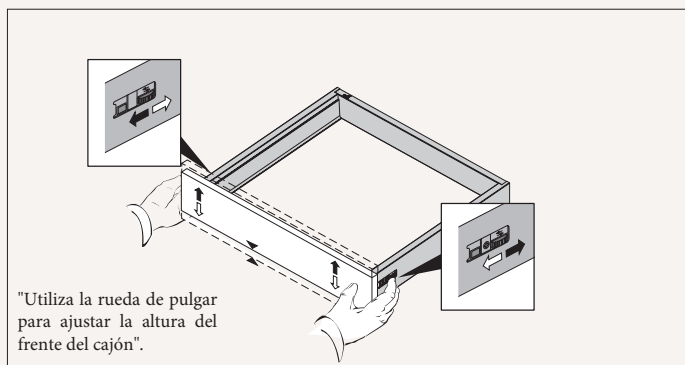

EN: Use the thumb wheel to adjust the height of the drawer front.
FR: Utilisez la molette pour régler la hauteur du devant du tiroir.
PT: Use a roda de polegar para ajustar a altura da frente da gaveta.

AJUSTE LATERAL

EN: Lateral adjustment.
FR: Réglage latéral.
PT: Ajuste lateral.

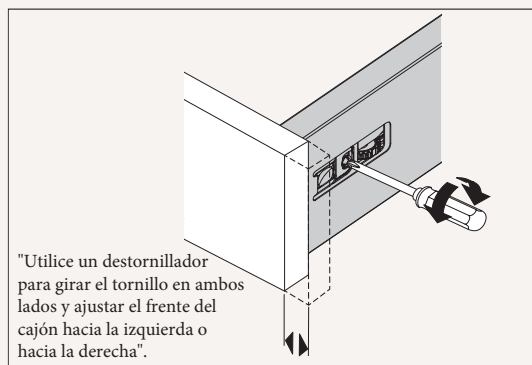

EN: Use a screwdriver to turn the screw on both sides and adjust the drawer front to the left or right.
FR: côté et ajuster le devant du tiroir vers la gauche ou vers la droite.
PT: Use uma chave de fenda para girar o parafuso de ambos os lados e ajustar a frente da gaveta para a esquerda ou para a direita.

AJUSTE DE INCLINACIÓN

EN: Tilt adjustment.
FR: Réglage de l'inclinaison.
PT: Ajuste de inclinação.

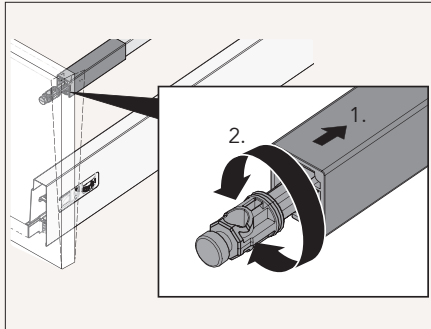

RETIRADA DEL RAIL

EN: Railing removal.
FR: Retrait du rail.
PT: Remoção do trilho.

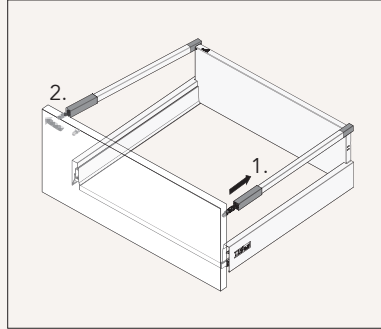

INSTALACIÓN DEL RAIL

EN: Railing installation.
FR: Installation du rail.
PT: Instalação do trilho

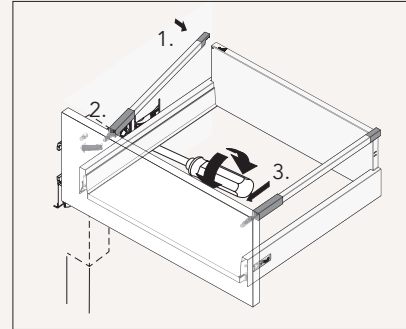

RETIRADA DEL FRENTE DEL CAJÓN

EN: Drawer front removal.
FR: Retrait du devant du tiroir
PT: Remoção da frente da gaveta

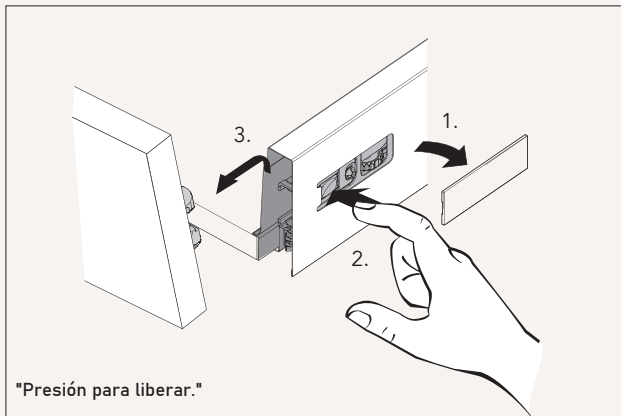

INSTALACIÓN DEL FRENTE DEL CAJÓN

EN: Drawer front installation.
FR: Retrait du devant du tiroir
PT: Remoção da frente da gaveta.

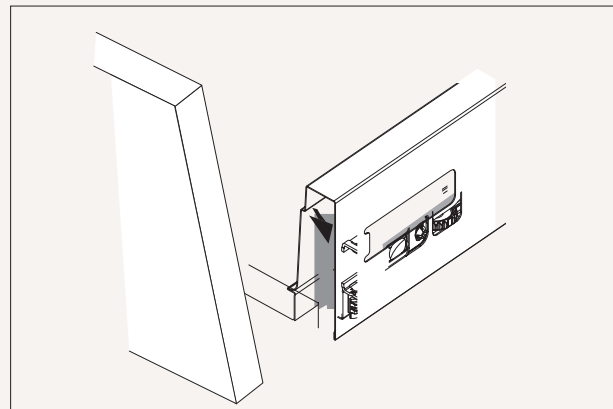

MANTENIMIENTO Y LIMPIEZA DE MUEBLES

EN: Maintenance and cleaning of furniture /**FR:** Entretien et nettoyage des meubles. /**PT:** Manutenção e limpeza de móveis.

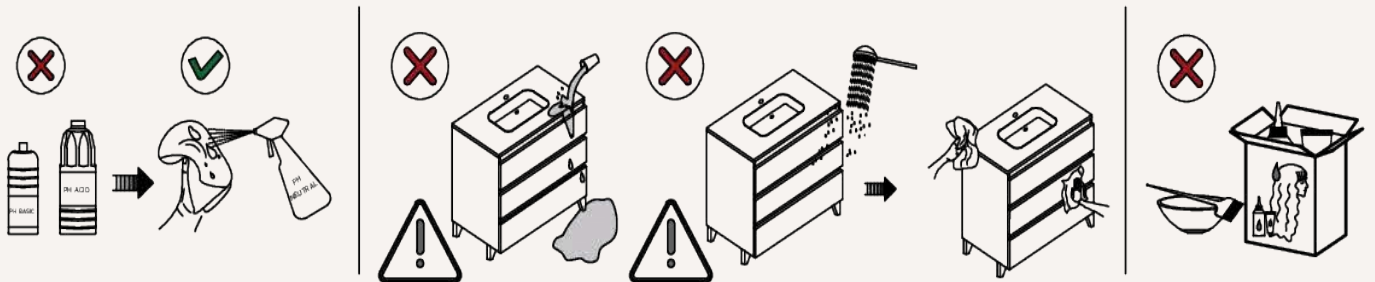

INSTALACIÓN Y REGULACIÓN DE MUEBLES

EN: Furniture installation and adjustment. /FR: Installation et réglementation des meubles. /PT: Instalação e regulação de móveis.

SEMICOLUMNNA

EN: Semi-column. /FR:semi-colonne. /PT:semi-coluna.

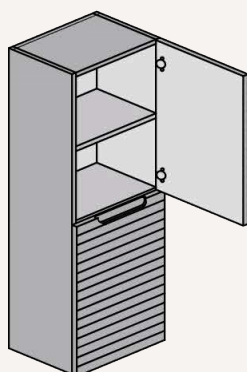

DESEMBALAJE

EN: Unpacking. /FR: Déballage. /PT: Desempacotando

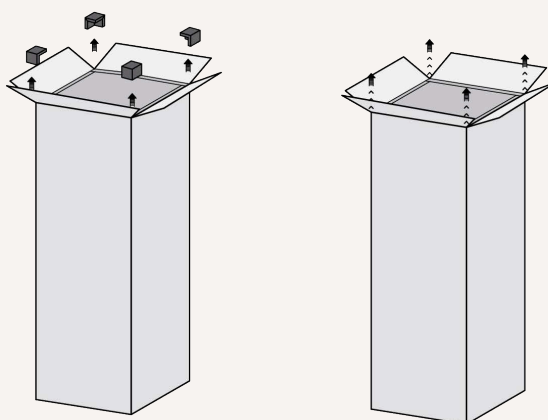

PLACA DE SUJECIÓN EN PARED

EN: Wall mounting plate. /FR: Plaque de fixation murale. /PT: Placa de fixação na parede.

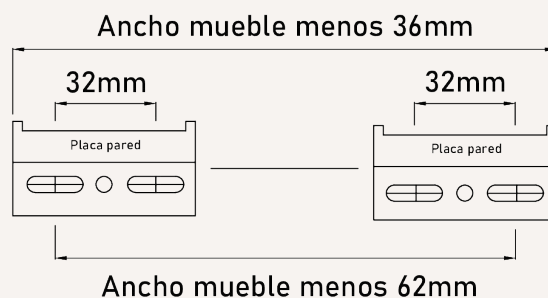

SUJECIÓN A PARED DE SEMICOLUMNA (COLGADOR SCARPI CON TAPA)

EN: Wall mounting of semi-column (Scarpi hanger with cover). **/FR:** Fixation murale de semi-colonne (porte-manteau Scarpi avec couvercle). **/PT:** Fixação na parede de semi-coluna (cabide Scarpi com tampa).

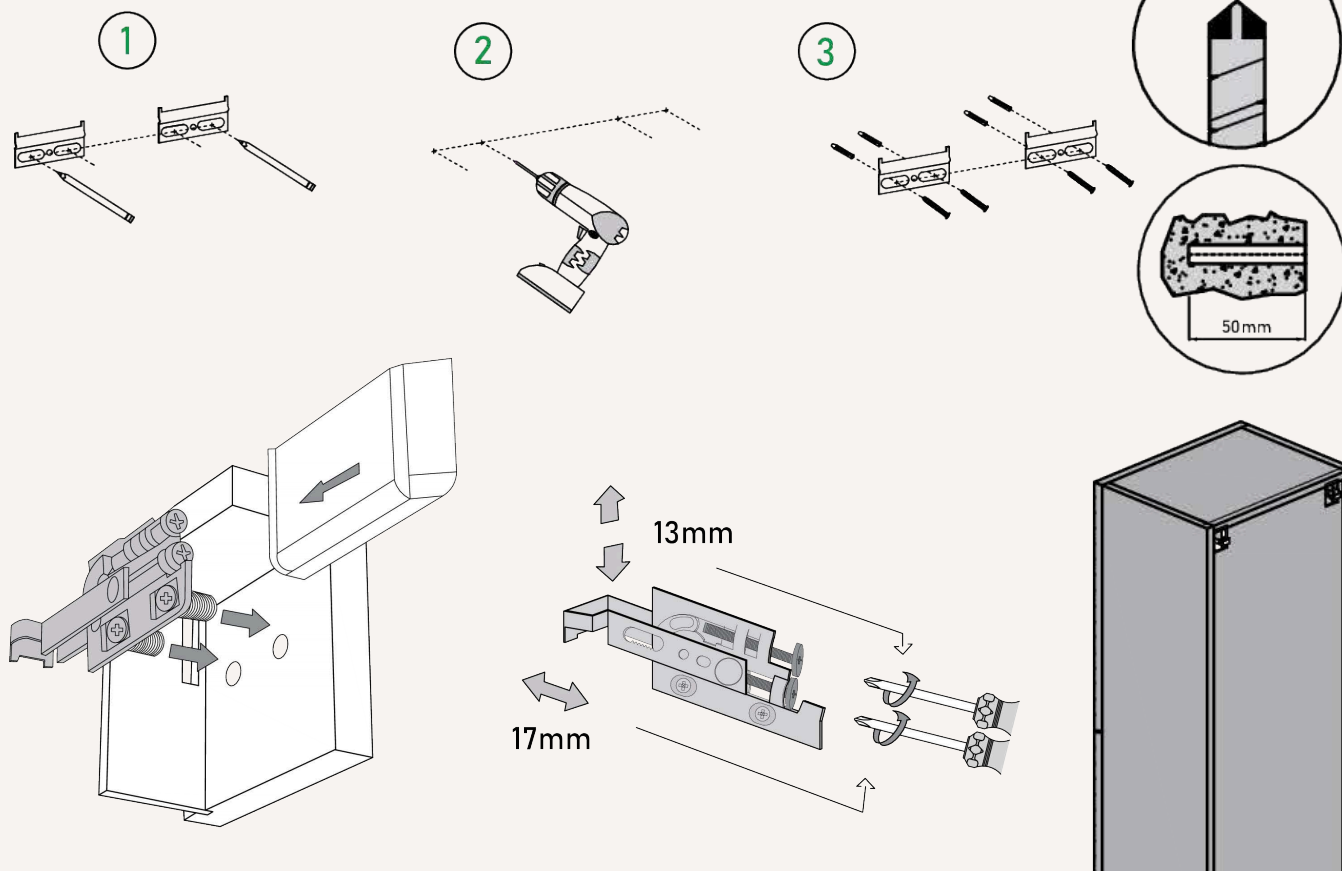
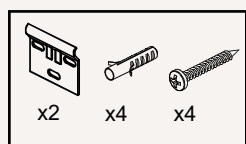

MANTENIMIENTO Y LIMPIEZA DE MUEBLES

EN: Maintenance and cleaning of furniture **/FR:** Entretien et nettoyage des meubles. **/PT:** Manutenção e limpeza de móveis.





WWW.MAESTREBANOS.COM

Polígono Industrial Cabezuelo 2
13440, Argamasilla de Calatrava (Ciudad Real)
926 44 25 24
maestrebamos@maestrebamos.com



La marca de la
gestión forestal
responsable