

Technical Data

RUANDA



maestre

BAÑOS



AVAILABLE MODELS



FRONT AND STRUCTURE FINISHES



DESERT

TECHNICAL SPECIFICATIONS

Structure: Made of 16 mm particle board with desert melamine.

Front: Made of 19mm MDF board, desert melamine with black base.

Handles: Finger pull milled into the front.

Mounting:

*Wall- hung: Includes 2 metal hangers for horizontal and vertical regulation.

*Floor- standing: Include 1 bag of 4 legs in matte graphite and its screws.

FEATURES



Organizer drawer

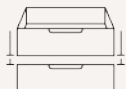

Adjustable drawer

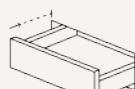

Soft close

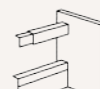

Hettich guides



Cleaning robot easy access



Finger pull



Quality guarantee

AVAILABLE MEASUREMENTS FOR FURNITURE OF 1 DRAWER (cm)

Front view

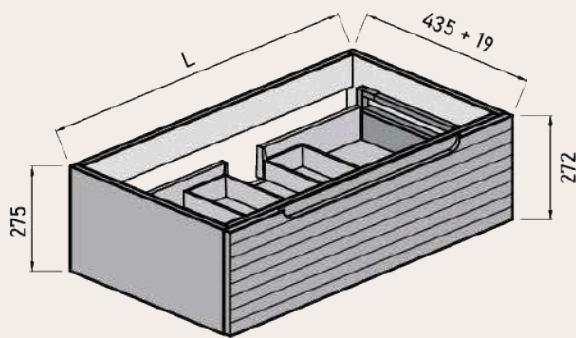

Back view

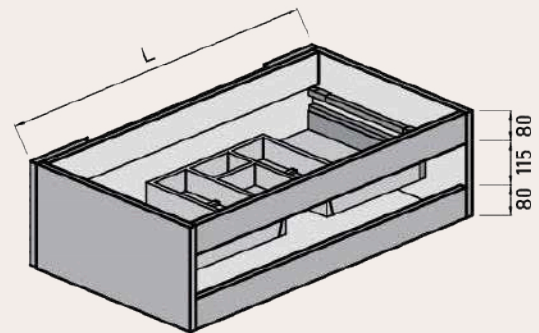

Upper drawer

	WIDTH	L	A1
UNIT	60	491	165
UNIT	80	691	265
UNIT	100	891	365

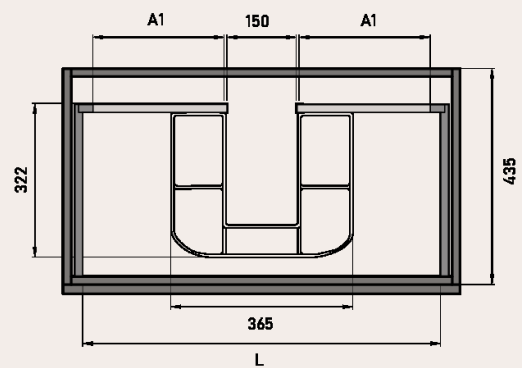

AVAILABLE MEASUREMENTS FOR FURNITURE OF 2 DRAWERS (cm)

Front view

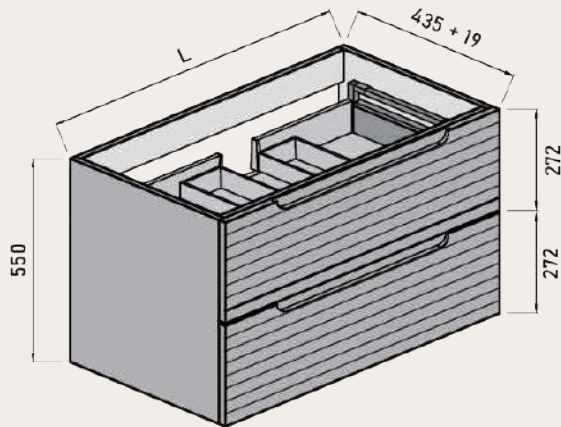

Back view

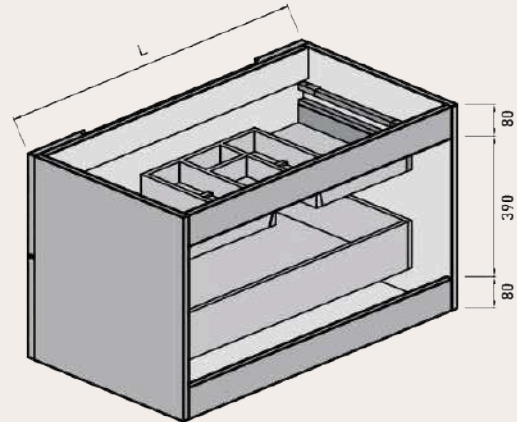

Upper drawer

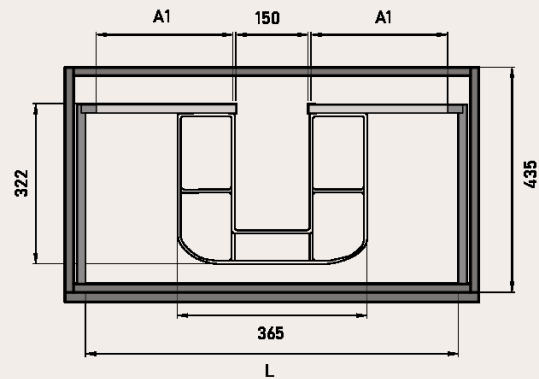

	WIDTH	L	A1
UNIT	60	491	165
UNIT	80	691	265
UNIT	100	891	365

AVAILABLE MEASUREMENTS FOR FURNITURE OF 3 DRAWERS (cm)

Front view

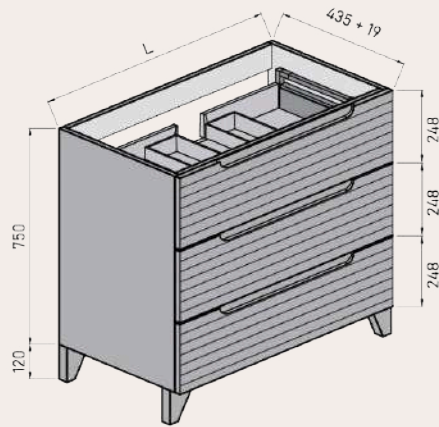

Back view

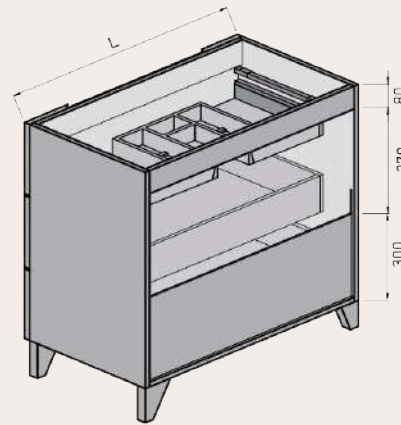

Upper drawer

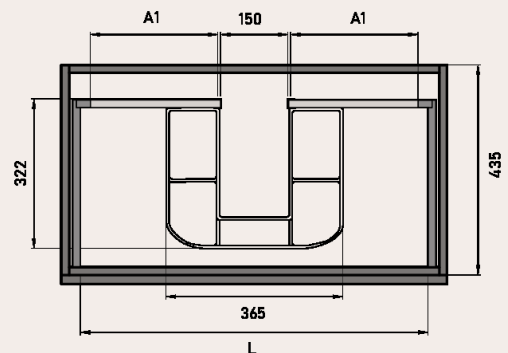

	WIDTH	L	A1
UNIT	60	491	165
UNIT	80	691	265
UNIT	100	891	365

AVAILABLE MEASUREMENTS FOR SEMI-COLUMN (cm)

Front view

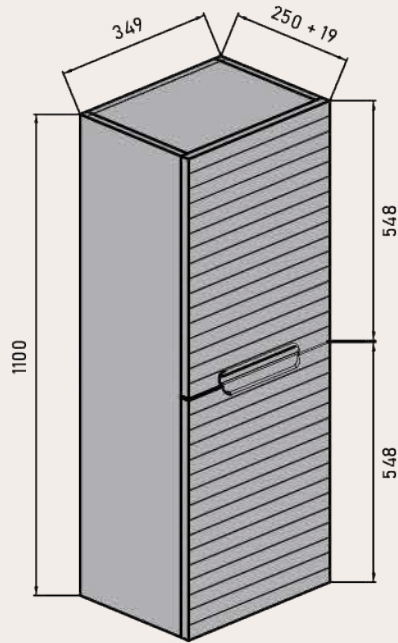

Back view

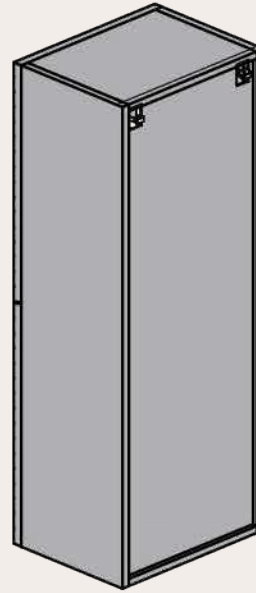

Front view (fixed shelves)

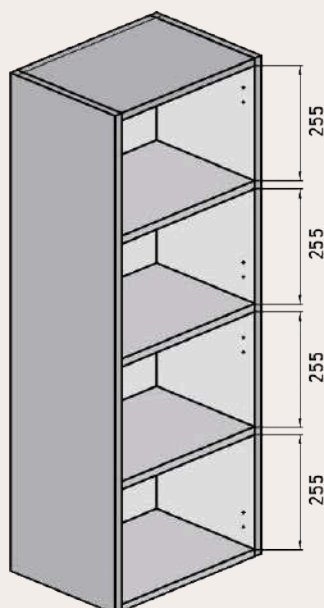

Front view (interior)

* The customer can change the door opening direction to the left.

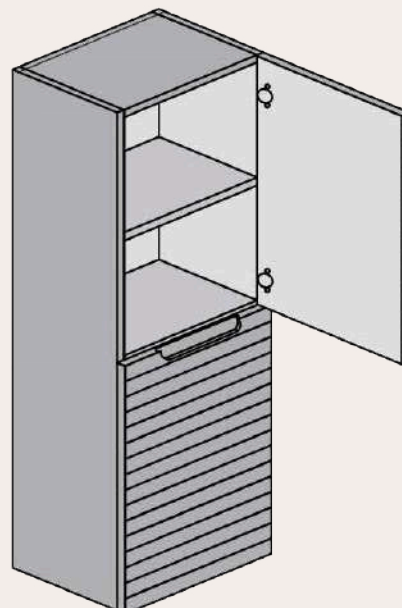

AVAILABLE MEASUREMENTS FOR MODUL (cm)

Shelf module: **Front view (fixed shelf)**

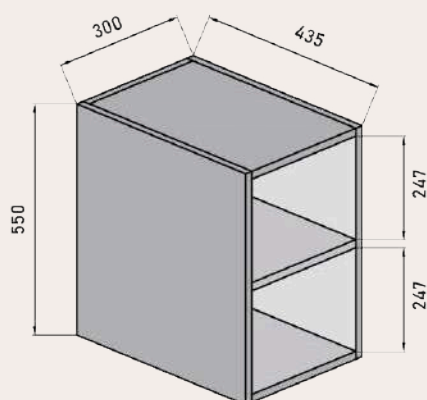

Front view FURNITURE PLUS SHELF MODULE

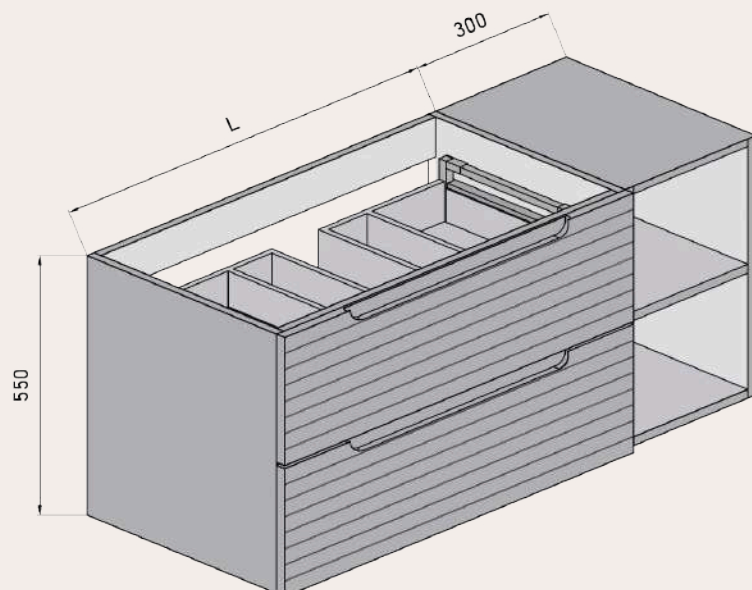



WWW.MAESTREBANOS.COM

Polígono Industrial Cabezuelo 2
13440, Argamasilla de Calatrava (Ciudad Real)
926 44 25 24
maestrebamos@maestrebamos.com



La marca de la
gestión forestal
responsable